

Model 2000 Pneumatic Volume Booster

Features

- The Model 2000 Pneumatic Volume Booster converts a low flow signal to a high flow output. It is ideally suited for a variety of applications including the operation of air systems that require rapid valve or cylinder action.
- A balanced Supply Valve minimizes the effect of supply pressure variation.
- An Aspirator Tube minimizes downstream pressure drop under flow conditions.
- Large Supply and Exhaust Valves provide high forward and exhaust flows.
- Soft Supply and Exhaust Valve Seats minimize air consumption.
- Small signal volume assures rapid response to pressure variation.
- A separate Control Chamber isolates the Diaphragm from the main flow to eliminate hunting and buzzing.
- Unit construction lets you service the unit without removing it from the line.



Operating Principles

When signal pressure on the top of the Signal Diaphragm creates a downward force on the Diaphragm Assembly, the Supply Valve opens.

Output pressure flows through the Outlet Port and the Aspirator Tube to the Control Chamber to create an upward force on the bottom of the Control Diaphragm. When the setpoint is reached, the force of the signal pressure that acts on the top of the Signal Diaphragm balances with the force of the output pressure that acts on the bottom of the Control Diaphragm to close the Supply Valve.

When the output pressure increases above the signal pressure, the Diaphragm Assembly moves upward to close the Supply Valve and open the Exhaust Valve. Because the Poppet Valve is closed, pressure flows down the Connecting Tube to the bottom of the Motor Diaphragm. This pressure keeps the Supply Valve tightly closed while in the exhaust mode. The Poppet Valve opens and excess output pressure exhausts through the vent in the side of the unit until it reaches the setpoint.

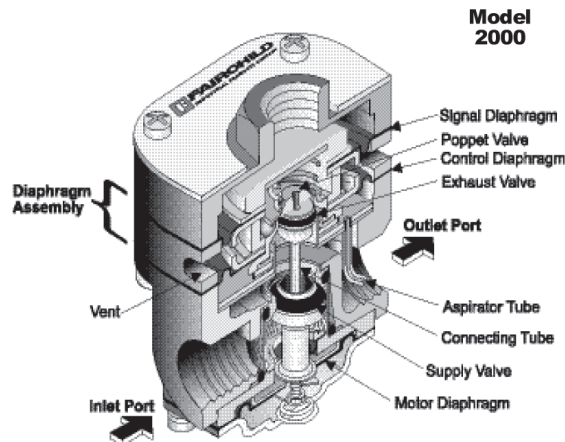

Model 2000

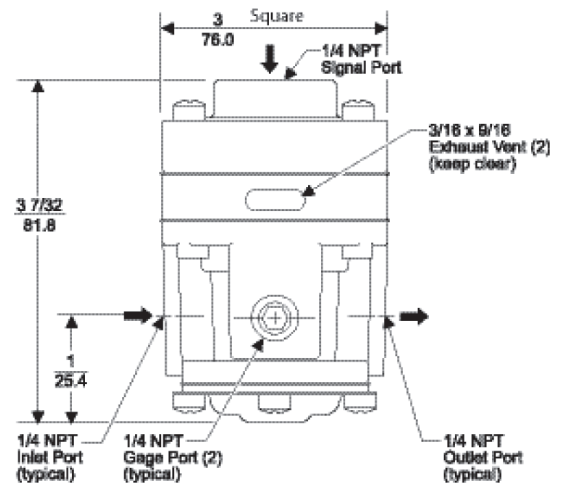

Specialists in Valves, Controls, Pneumatics, Fluid Measurement

