

# ASCO®

## Series 8314

General Purpose Solenoid Valves

### Applications

- Process valve automation
- Fluid diversion
- Fluid mixing
- Piloting applications



### Features & Benefits

- **Higher Pressure Ratings:** Increased performance on OEM equipment for Air, Inert Gas, and most liquids
  - Average AC ratings up to 50% greater than existing valves
  - Average DC ratings up to 170% greater than existing valves
- **Agency Approvals:** UL, CSA, and CE approvals with most coil and elastomer options
- **Increased Ambient Temperature Range:** Valves can now be used in more environments
  - Min. ambient temperature of -13°F (-25°C) standard for air and gas applications<sup>①</sup>
  - AC max. ambient temperature of 140°F (60°C) standard<sup>②</sup>
  - DC max. ambient temperature of 131°F (55°C) standard
- **Easy Installation and Mounting:** 5mm tapped holes on body provide quick and easy mounting to any flat surface
- **Most constructions available as part of the ASCO Today program or 5-Day program to help keep production lines running smoothly**

### Specifications

Product Range	Pipe Sizes (in)	Flow (Cv)	Pressure Range (psi) Air / Water / Lt. Oil		Ambient Temp. Range (°F)	
			AC	DC	AC	DC
3-Way - Brass - Stainless Steel	1/8", 1/4"	0.05 to 0.85	0 to 300	0 to 300	Class F -13°F to 131°F <sup>②</sup> Class H -13°F to 140°F	-13°F to 131°F -13°F to 131°F

① -13°F (-25°C) applies to standard BUNA-N version. Allowable leakage of 3 SCFH. No leakage at -4°F (-20°C)

② Maximum ambient temperature for AC Class F explosionproof (EF & EV) is 125°F (52°C)



## General Service Solenoid Valves

Direct Acting  
Brass or Stainless Steel Bodies  
1/8" and 1/4" NPT

3/2  
SERIES  
8314

### Features

- No minimum operating pressure required
- The original 3-way valve design
- Simplest valve for basic 3-way piloting operation, only a spring and two moving parts
- Moderate flow pilots, smaller control valves and actuators
- Can also be used for low-volume fluid diversion
- High speed general service

### Construction

Valve Parts in Contact with Fluids		
Body	Brass	Cast 304 Stainless Steel
Seals and Discs	NBR (Upper Disk - FKM)	
Core Tube	305 Stainless Steel	
Core and Plugnut	430F Stainless Steel	
Core Springs	302 Stainless Steel	
Shading Coil	Copper	Silver
Core Guide	CA	

### Electrical

Standard Coil and Class of Insulation	Watt Rating and Power Consumption				Spare Coil Part Number			
	DC Watts	AC			General Purpose		Explosionproof	
		Watts	VA Holding	VA Inrush	AC	DC	AC	DC
F	11.6	10.1	25	50	238610	238710	238614	238714

**Standard Voltages:** 24, 120, 240, 480 volts AC, 60 Hz (or 110, 220, 440 volts AC, 50 Hz).  
6, 12, 24, 120, 240 volts DC. Must be specified when ordering. Other voltages are available when required.

### Solenoid Enclosures

**Standard:** Watertight, Types 1, 2, 3, 3S, 4, and 4X.

**Optional:** Explosionproof and Watertight, Types 3, 3S, 4, 4X, 6, 6P, 7, and 9.  
(To order, add prefix "EF" to catalog number.)

See *Optional Features Section* for other available options.

### Options

- Mounting bracket (suffix MB)
- Quarter-turn manual operator with screw slot (suffix MS)
- Viton (suffix V)
- Oxygen (suffix N)
- Silicon Free (suffix SF)

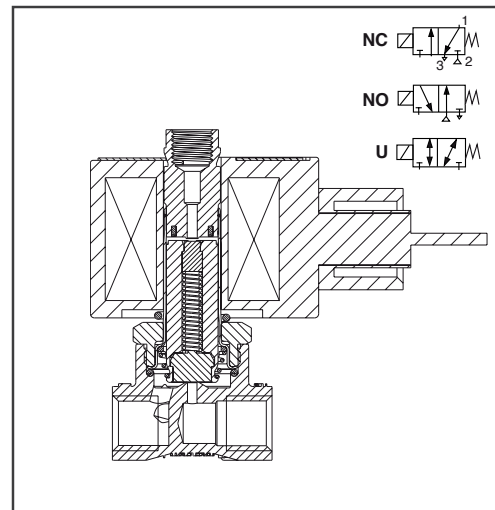

### Nominal Ambient Temp. Ranges

The nominal limitation of 32°F (0°C) is advisable for any valve that might contain moisture (water vapor).

AC: -13°F to 131°F (-25°C to 55°C)\*

DC: -13°F to 131°F (-25°C to 55°C)

\*Max. ambient for explosionproof (EF) is 125°F (52°C)

Optional: For AC, the max. ambient temperature is 140°F (60°C) with Class H coil (with or without prefix EF)

Refer to *Engineering Section* for details.

### Approvals

CSA certified. UL listed General Purpose Valves.

Meets applicable CE directives.

SIL 3 capable per IEC 61508 on normally closed const.

Third party certification provided by EXIDA.

Refer to *Engineering Section* for details.

## 3/2 SERIES 8314



### Specifications (English units)

Pipe Size (ins.)	Orifice Size (ins.)	Cv Flow Factor 2-1	Cv Flow Factor 1-3	Operating Pressure Differential (psi)						Max. Fluid Temp. °F		Brass Body		Stainless Steel Body		Watt Rating/ Class of Coil Insulation	
				Max. AC			Max. DC					Catalog Number	Const. Ref.	Catalog Number	Const. Ref.		
				Air-Inert Gas	Water	Light Oil @ 45 SSU	Air-Inert Gas	Water	Light Oil @ 45 SSU	AC	DC						
<b>Universal Operation (Pressure at any port)</b>																	
1/8	3/64	0.05	0.06	200	200	200	200	200	200	200	200	8314H041	1	8314H042	1	10.1/F	11.6/F
1/8	3/32	0.15	0.20	105	85	60	105	85	60	200	200	8314H043	1	8314H044	1	10.1/F	11.6/F
1/8	1/8	0.25	0.20	70	70	40	55	45	45	200	200	8314H045	1	8314H040	1	10.1/F	11.6/F
1/4	3/64	0.05	0.06	200	200	200	200	200	200	200	200	8314H006	2	8314H123	2	10.1/F	11.6/F
1/4	3/32	0.15	0.20	105	85	60	105	85	60	200	200	8314H007	2	8314H120	2	10.1/F	11.6/F
1/4	1/8	0.25	0.20	70	70	40	55	45	45	200	200	8314H008	2	8314H124	2	10.1/F	11.6/F
<b>Normally Closed (Closed when de-energized) – PFD<sub>AVG</sub> = 4.77 x 10<sup>-4</sup></b>																	
1/8	3/64	0.05	0.06	300	300	300	250	250	250	200	200	8314H031	1	8314H037	1	10.1/F	11.6/F
1/8	3/32	0.15	0.20	205	205	190	150	120	90	200	200	8314H032	1	8314H038	1	10.1/F	11.6/F
1/8	1/8	0.25	0.20	145	145	100	90	90	70	200	200	8314H033	1	8314H039	1	10.1/F	11.6/F
1/4	3/64	0.05	0.06	300	300	300	250	250	250	200	200	8314H034	2	8314H068	2	10.1/F	11.6/F
1/4	3/32	0.15	0.20	205	205	190	150	120	90	200	200	8314H035	2	8314H121	2	10.1/F	11.6/F
1/4	1/8	0.25	0.20	145	145	100	90	90	70	200	200	8314H036	2	8314H126	2	10.1/F	11.6/F
<b>Normally Open (Open when de-energized)</b>																	
1/8	3/64	0.05	0.06	300	300	300	250	250	250	200	200	8314H049	1	8314H055	1	10.1/F	11.6/F
1/8	3/32	0.15	0.20	175	175	175	160	160	160	200	200	8314H050	1	8314H056	1	10.1/F	11.6/F
1/8	1/8	0.25	0.20	160	160	160	150	150	120	200	200	8314H051	1	8314H057	1	10.1/F	11.6/F
1/4	3/64	0.05	0.06	300	300	300	250	250	250	200	200	8314H052	2	8314H069	2	10.1/F	11.6/F
1/4	3/32	0.15	0.20	175	175	175	160	160	160	200	200	8314H053	2	8314H122	2	10.1/F	11.6/F
1/4	1/8	0.25	0.20	160	160	160	150	150	120	200	200	8314H054	2	8314H070	2	10.1/F	11.6/F

### Specifications (Metric units)

Pipe Size (ins.)	Orifice Size (ins.)	Kv Flow Factor 2-1	Kv Flow Factor 1-3	Operating Pressure Differential (bar)						Max. Fluid Temp. °C		Brass Body		Stainless Steel Body		Watt Rating/ Class of Coil Insulation	
				Max. AC			Max. DC					Catalog Number	Const. Ref.	Catalog Number	Const. Ref.		
				Air-Inert Gas	Water	Light Oil @ 45 SSU	Air-Inert Gas	Water	Light Oil @ 45 SSU	AC	DC						
<b>Universal Operation (Pressure at any port)</b>																	
1/8	1.2	0.04	0.05	14	14	14	14	14	14	93	93	8314H041	1	8314H042	1	10.1/F	11.6/F
1/8	2.4	0.13	0.17	7	6	4	7	6	4	93	93	8314H043	1	8314H044	1	10.1/F	11.6/F
1/8	3.2	0.22	0.17	5	5	3	4	3	3	93	93	8314H045	1	8314H040	1	10.1/F	11.6/F
1/4	1.2	0.04	0.05	14	14	14	14	14	14	93	93	8314H006	2	8314H123	2	10.1/F	11.6/F
1/4	2.4	0.13	0.17	7	6	4	7	6	4	93	93	8314H007	2	8314H120	2	10.1/F	11.6/F
1/4	3.2	0.22	0.17	5	5	3	4	3	3	93	93	8314H008	2	8314H124	2	10.1/F	11.6/F
<b>Normally Closed (Closed when de-energized) – PFD<sub>AVG</sub> = 4.77 x 10<sup>-4</sup></b>																	
1/8	1.2	0.04	0.05	21	21	21	17	17	17	93	93	8314H031	1	8314H037	1	10.1/F	11.6/F
1/8	2.4	0.13	0.17	14	14	13	10	8	6	93	93	8314H032	1	8314H038	1	10.1/F	11.6/F
1/8	3.2	0.22	0.17	10	10	7	6	6	5	93	93	8314H033	1	8314H039	1	10.1/F	11.6/F
1/4	1.2	0.04	0.05	21	21	21	17	17	17	93	93	8314H034	2	8314H068	2	10.1/F	11.6/F
1/4	2.4	0.13	0.17	14	14	13	10	8	6	93	93	8314H035	2	8314H121	2	10.1/F	11.6/F
1/4	3.2	0.22	0.17	10	10	7	6	6	5	93	93	8314H036	2	8314H126	2	10.1/F	11.6/F
<b>Normally Open (Open when de-energized)</b>																	
1/8	1.2	0.04	0.05	21	21	21	17	17	17	93	93	8314H049	1	8314H055	1	10.1/F	11.6/F
1/8	2.4	0.13	0.17	12	12	12	11	11	11	93	93	8314H050	1	8314H056	1	10.1/F	11.6/F
1/8	3.2	0.22	0.17	11	11	11	10	10	8	93	93	8314H051	1	8314H057	1	10.1/F	11.6/F
1/4	1.2	0.04	0.05	21	21	21	17	17	17	93	93	8314H052	2	8314H069	2	10.1/F	11.6/F
1/4	2.4	0.13	0.17	12	12	12	11	11	11	93	93	8314H053	2	8314H122	2	10.1/F	11.6/F
1/4	3.2	0.22	0.17	11	11	11	10	10	8	93	93	8314H054	2	8314H070	2	10.1/F	11.6/F



3/2  
SERIES  
8314

Dimensions: inches (mm)

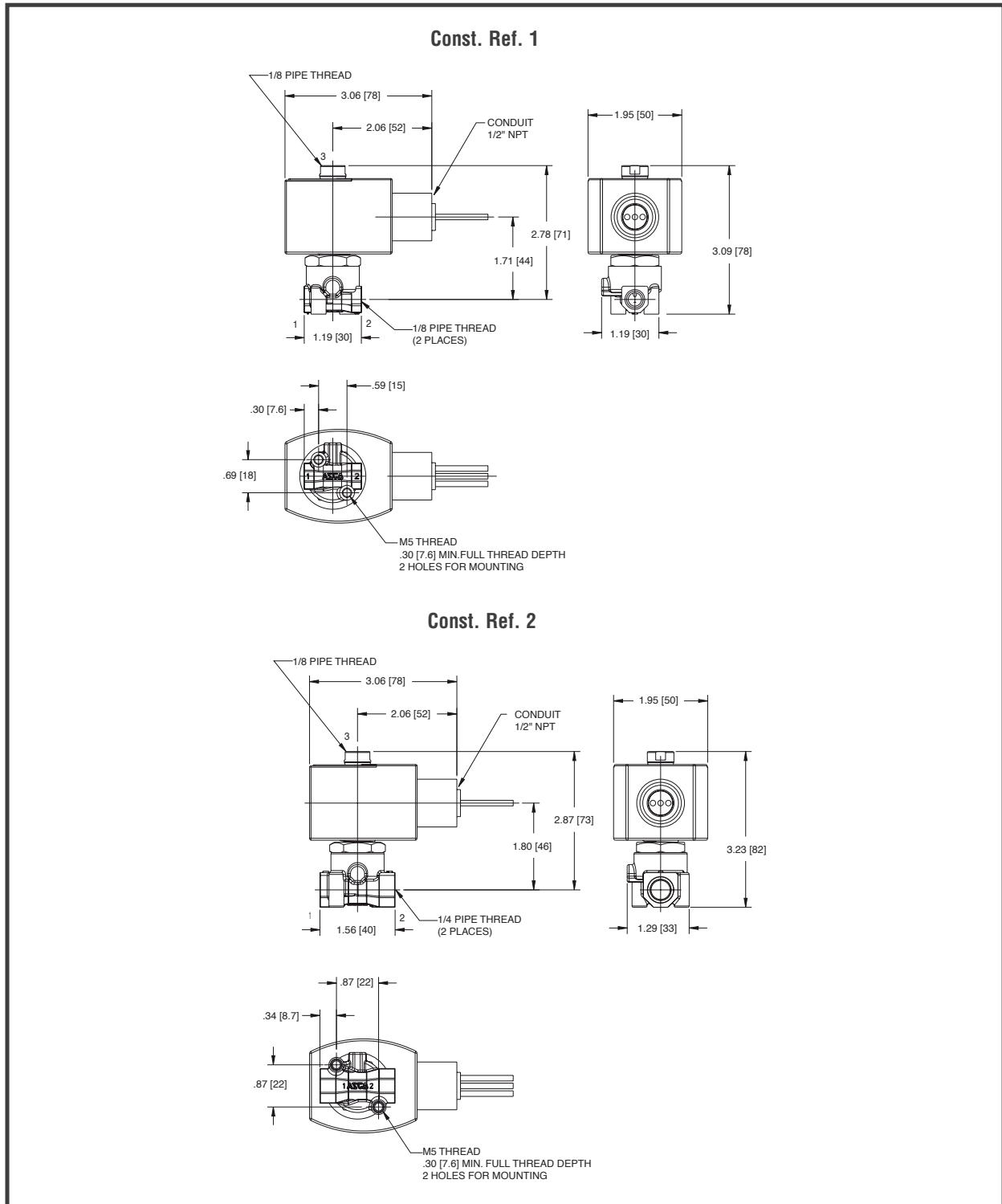

3/2  
SERIES  
8314

ASCO®

Flow Diagrams

