

FAIRCHILD MODEL 10 PNEUMATIC PRECISION REGULATOR

Installation, Operation and Maintenance Instructions

Tamper Proof

Plunger Operated

Identification Number 10 2

Pressure Range _____

psig	[BAR]	(kPa)	
0-2	[0-.15]	(0-15)	(1)
0-10	[0-0.7]	(0-70)	(2)
0-20	[0-1.5]	(0-150)	(0)
.5-30	[.03-2]	(3-200)	(3)
1-60	[.10-4]	(10-400)	(4)
2-150	[.15-10]	(15-1000)	(6)
3-200	[.20-14]	(20-1400)	(7)
5-300	[.35-21]	(35-2100)	(8)
5-400	[.35-28]	(35-2800)	(9)

Pipe Size _____

1/4" NPT (2)
3/8" NPT (3)
1/2" NPT (4)

Options _____

Compatibility Options Y = Yes N = No

	T	E	L	R	N	B	C	A	J	U	H	P
(T)	-	Y	Y	N	Y	Y	Y	Y	Y	Y	Y	N
(E)	Y	-	Y	N	Y	Y	Y	Y	Y	Y	Y	Y
(L)	Y	Y	-	Y	N	N	Y	Y	Y	Y	Y	Y
(R)	N	N	Y	-	Y	Y	Y	Y	Y	Y	Y	N
(N)	Y	Y	N	Y	-	N	N	Y	Y	Y	Y	Y
(B)	Y	Y	N	Y	N	-	N	Y	Y	Y	Y	Y
(C)	Y	Y	Y	Y	N	N	-	Y	Y	Y	Y	Y
(A)	Y	Y	Y	Y	Y	Y	-	N	Y	Y	Y	Y
(J)	Y	Y	Y	Y	Y	Y	Y	N	-	Y	Y	Y
(U)	Y	Y	Y	Y	Y	Y	Y	Y	Y	-	-	Y
(H)	Y	Y ³	Y	Y	Y	Y	Y	Y	Y	N	-	Y
(P)	N	Y	Y	N	Y	Y	Y	Y	Y	Y	Y	-

Tamper Proof
Tapped Exhaust
Low Flow
Plunger Operated
Non-Relieving
Low Bleed
Check Valve¹
Silicone Elastomers²
Fluorocarbon
BSPT (Tapered)
BSPP (Parallel)³
Panel Mount

¹ Maximum Supply Pressure - 250 psig [17.0 BAR] (1700 kPa)
² Maximum Supply Pressure - 75 psig [5.0 BAR] (500 kPa)
³ BSPP Threads in Inlet & Outlet Ports Only. Others BSPT.

Figure 1. Model 10 Pneumatic Pressure Regulator Identification Number System.

GENERAL INFORMATION

The Model 10 is a high capacity regulator that provides a uniform output pressure independent of supply pressure variation.

ADJUSTMENTS

The Model 10 Regulator does not require field adjustments.

SPECIFICATIONS

Functional Specifications			
Supply Pressure	psig	[BAR]	(kPa)
Maximum (A Option)	500	[35]	(3500)
	75	[5.0]	(500)

Specifications (continued)

Flow Capacity (Nominal)	40 SCFM (68m ³ /HR) @ 100 psig [7 BAR] (700 kPa) Supply & 20 psig [1.5 BAR] (150 kPa) Set.
Exhaust Capacity	5 1/2 SCFM (9.4m ³ /HR) @ downstream pressure 5 psig [.35 BAR] (35 kPa) above 20 psig [1.5 BAR] (150 kPa) Set Pressure.
Sensitivity	Less than 0.125" (.32 cm) Water Column
Ambient Temperature Limits	-40°F to +200°F (-40° C to +93.2° C)
Performance Specifications	
Supply Pressure Effect	Less than .1 psig [.007 BAR] (.7 kPa) for 100 psig [7 BAR] (700 kPa) Change.
Materials of Construction	Body and Housing Aluminum Trim Stainless Steel, Brass, Zinc Plated Steel Diaphragms Buna N on Dacron (Standard Unit Only)

INSTALLATION

Clean all pipelines to remove dirt and scale before installation.

Apply a minimum amount of pipe compound to the male threads of the fitting only. Start with the third thread back and work away from the end of the fitting to avoid the possibility of contaminating the regulator. Install the regulator in the air line.

You can mount the Model 10 regulator in any position without affecting its operation. To panel mount the unit, use the two 1/4"-20 holes in the bonnet. You can wall mount the regulator using using Mounting Bracket 09921 shown in Figure 3.

The inlet and outlet connections are labeled on the underside of the regulator with the arrows pointing in the direction of the flow. Tighten connections securely. Avoid undersized fittings that will limit the flow through the regulator and cause a pressure drop downstream. For more information, see Figure 2. "Outline Dimensions".

NOTE: Oil free air must be applied to the regulator. Use a filter to remove dirt and entrained liquid in the air line ahead of the regulator. If an air line lubricator is used, it MUST be located downstream of the regulator, to avoid interference with regulator performance.

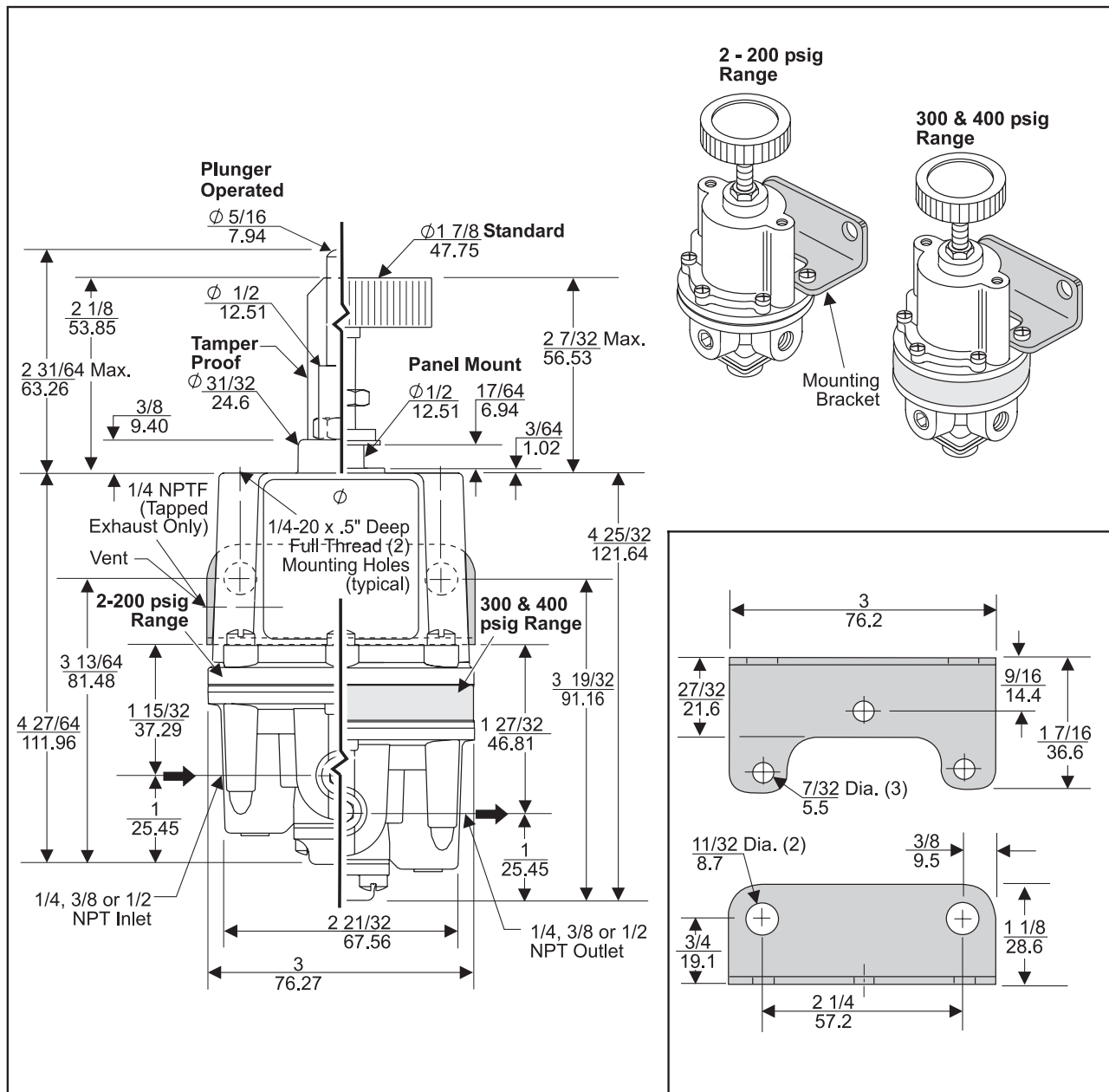

Figure 2. Outline Dimensions

Figure 3. Mounting Bracket 09921
(Sold Separately)

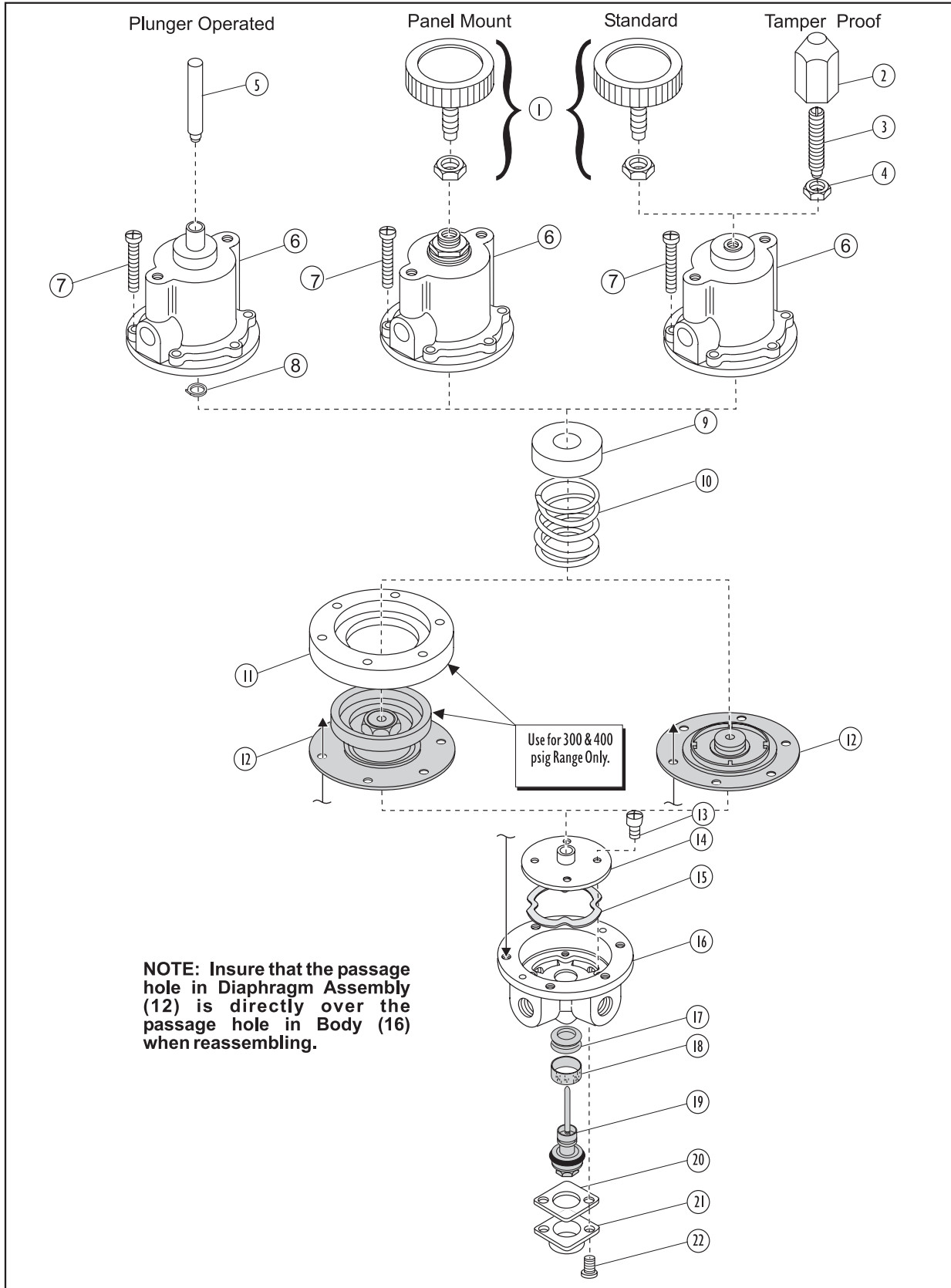

Figure 4. Exploded Drawing

MAINTENANCE

To clean the Model 10, use the following procedure:

1. Before disassembly, shut off the valve that is supplying air to the regulator. This is to prevent air from escaping. **It is not necessary to remove the regulator from the air line.**
2. Remove the two Screws (22) from bottom of the unit.
3. Pull out the Inner Valve Assembly (19). Wash the Seat on the Inner Valve Assembly carefully.
4. Wipe off any particles that may be attached to rubber Seat Ring (17) in Body.
5. Replace the assembly carefully.
6. Keep the vent hole in the Bonnet clear for proper regulator operation. Lubricate the adjusting screw with Molycote "G". For more information, see Figure 4. "Exploded Drawing" on page 3.

NOTES: Avoid such solvents as acetone, carbon tetrachloride and trichlorethylene.

If the standard maintenance procedure does not correct the problem install service kit.

TROUBLE-SHOOTING

Table 1. Trouble-Shooting	
Problem	Solution (check)
Leakage	Body Screw tightness. Diaphragm.
High Bleed	Relief Pintle and Relief Seat for damage or contamination.
Valve Chatter	Seal Ring lubrication.

HAZARDOUS LOCATION INSTALLATIONS

Table 2. Hazardous Location	
Information Required	Description Detail
Hazardous Locations	Group II, Category 2, Gas and Dusts: Zones 1, 2 and 21,22, respectively Gas Groups IIA and IIB
Ambient Temperature Range	Use must be evaluated for the relevant flammable gas temperature code
Cleaning	Clean with damp cloth
Grounding	Units must be grounded to earth ground
Codes of Practice	PDCLC/TR 50404:2003 BS 5958

LEGAL NOTICE

The information set forth in the foregoing Installation, Operation and Maintenance Instructions shall not be modified or amended in any respect without prior written consent of Fairchild Industrial Products Company. In addition, the information set forth herein shall be furnished with each product sold incorporating Fairchild's unit as a component thereof.