

A Model 30 Midget Precision Regulator

Model 30



The Model 30 is designed for applications that require high capacity and accurate process control. A supply valve which is balanced by utilizing a rolling diaphragm, insures a constant output pressure even during wide supply pressure variations. Stability of regulated pressure is maintained under varying flow conditions through the use of an aspirator tube which adjusts the supply valve in accordance with the flow velocity.

Features

- Control sensitivity of 1/4" water column variation allows use in precision applications.
- Pressure Balanced Supply Valve lets the regulator remain unaffected by supply pressure changes.
- Flow of up to 40 SCFM with 100 psig supply allows use in applications with high flow requirements.
- An aspirator tube compensates downstream pressure droop under flow conditions.
- A separate Control Chamber isolates the diaphragm from the main flow to eliminate hunting and buzzing.
- Unit construction lets you service the Model 30 without removing it from the line.
- Canadian Registration Number (CRN) Certification for all territories and provinces.

Operating Principles

The Model 30 Regulator uses the force balance principal to control the movement of the valve assembly which in turn controls the output pressure. When the regulator is adjusted for a specific set point, the downward force of the Range Spring causes the Diaphragm Assembly to move downward. The Supply Valve opens and allows air to pass to the Outlet Port. As the set point is reached, the downward force exerted by the Range spring is balanced by the upward force of the downstream pressure acting on the bottom of the Diaphragm Assembly. The resultant force moves the supply Valve upward to reduce the flow of air to the Outlet Port.

Outlet pressure is maintained as a result of balance between forces acting on the top and bottom of the Diaphragm Assembly.

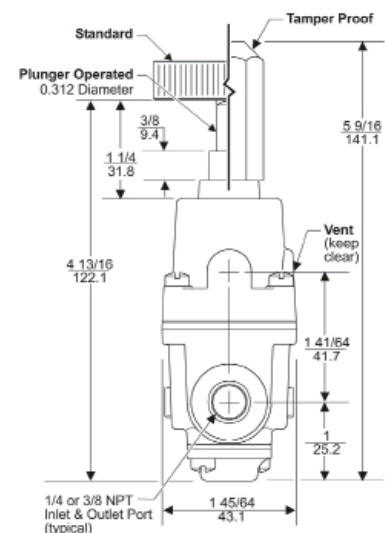
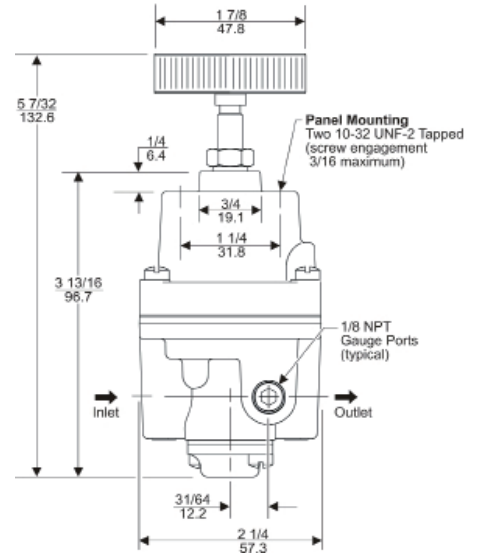
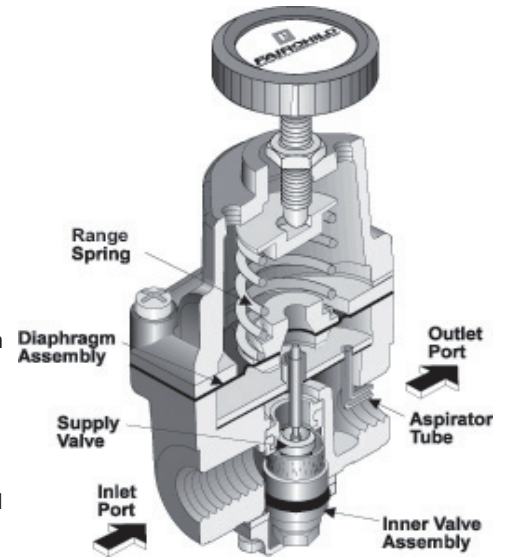

Model 30 Midget Precision Regulator



Technical Information

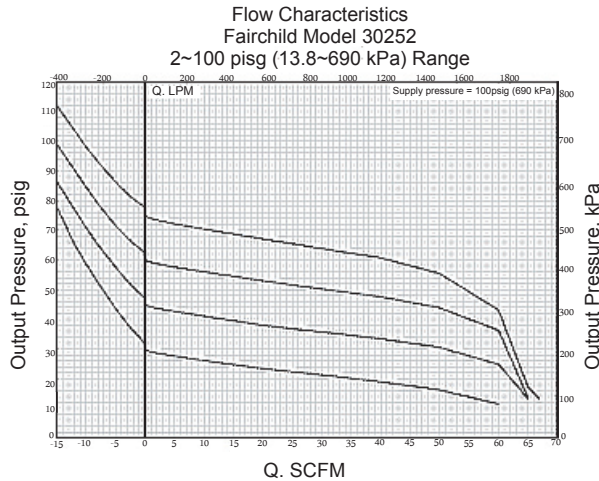

Specifications

Supply Pressure

250 psig, [17.0 BAR], (1700 kPa) Maximum

Flow Capacity

40 SCFM (68 m³/HR) @ 100 psig, [7.0 BAR], (700 kPa) supply and 20 psig, [1.5 BAR], (150 kPa) setpoint

Exhaust Capacity

2.0 SCFM (3.4 m³/HR) where downstream pressure is 5 psig, [.35 BAR], (35 kPa) above 20 psig, [1.5 BAR], (150 kPa) setpoint

Supply Pressure Effect

Less than 0.2 psig, [.014 BAR], (.14 kPa) for 100 psig, [7.0 BAR], (700 kPa) change in supply pressure

Sensitivity

1/4" (.63cm) Water Column

Ambient Temperature

-40°F to +200°F, (-40°C to 93.3°C)

Hazardous Locations

Acceptable for use in Zones 1 and 2 for gas atmosphere:
Groups IIA and IIB and Zones 21 and 22 for dust atmospheres

Materials of Construction

Body and Housing Aluminum
Diaphragms Nitrile on Dacron
Trim Brass

Model 30 Mounting Bracket P/N 21667-1

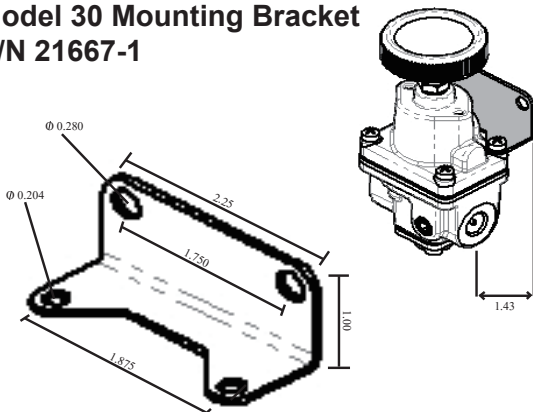

Catalog Information

Catalog Number

3 0 2

Pressure Range

psig	[BAR]	(kPa)	
0-2	[0-0.1]	(0-15)	1
0-10	[0-0.7]	(0-70)	2
0.5-30	[0.03-2]	(3-200)	3
1-60	[0.1-4]	(10-400)	4
2-100	[0.1-7]	(15-700)	5

Pipe Size

1/4" NPT	2
3/8" NPT	3

Options

- Silicone Elastomers ¹
- Low Bleed
- BSPP (Parallel) ²
- Fluorocarbon *Elastomers
- Low Flow
- Mounting Bracket
- Non-Relieving
- Plunger Operated ³
- Screwdriver Adjust
- Tamper Proof
- BSPT (Tapered)

	A	B	H	J	L	M	N	R	S	T	U
A	-	Y	Y	N	Y	Y	Y	Y	Y	Y	Y
B	Y	-	Y	Y	N	Y	N	N	Y	Y	Y
H	Y	Y	-	Y	Y	Y	Y	Y	Y	Y	N
J	N	Y	Y	-	Y	Y	Y	Y	Y	Y	Y
L	Y	N	Y	Y	-	Y	N	Y	Y	Y	Y
M	Y	N	Y	Y	Y	-	Y	Y	Y	Y	Y
N	Y	N	Y	Y	N	Y	-	Y	Y	Y	Y
R	Y	Y	Y	N	Y	Y	Y	-	Y	N	Y
S	Y	Y	Y	Y	Y	Y	Y	N	-	N	Y
T	Y	Y	Y	Y	Y	Y	Y	N	N	-	Y
U	Y	Y	N	Y	Y	Y	Y	Y	Y	Y	-

Option Compatibility Chart: "Y" in Box = Compatible options

¹ Maximum Supply Pressure - 75 psig, [5.0 BAR], (500 kPa)

² BSPP Threads in Inlet & Outlet Ports Only. Others BSPT.

³ Refer to Table 1 for Push Rod Travel and Thrust

* Viton

Table 1. Plunger Operated Regulator Parameters

Range	Push Rod Travel (inches)	Push Rod Thrust (pounds)
0-2 psig	.244 ± 10%	3.2 ± 10%
0-10 psig	.344 ± 10%	15.7 ± 10%
0-30 psig	.333 ± 10%	47.0 ± 10%
0-60 psig	.395 ± 10%	94.0 ± 10%
0-100 psig	.354 ± 10%	157.0 ± 10%

Installation

For installations instructions, refer to the *Fairchild Model 30 Midget Precision Regulator Instruction, Operation and Maintenance Instructions, IS-10000030*.