

Model 4500A Pneumatic Volume Booster

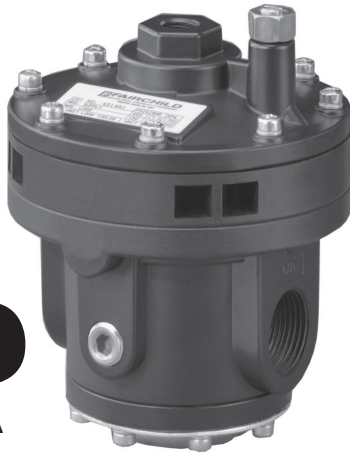

Features

- Five signal to output ratios meet most control element requirements.
- Control sensitivity of 1" water column allows use in precision applications.
- Large Supply and Exhaust Valves provide high forward and exhaust flows.
- Soft Supply and Exhaust Valve seats minimize air consumption.
- A balanced Supply Valve minimizes the effect of supply pressure variation.
- An Aspirator Tube compensates down stream pressure droop under flow conditions.
- A separate Control Chamber isolates the diaphragm from the main flow to eliminate hunting and buzzing.
- Optional remote feedback port minimizes pressure drop at final control element under flow conditions.
- Optional Adjustable By-Pass Needle Valve option includes bubble tight exhaust valve allows tuning for optimum dynamic response (1:1 ratio only) and cycle free operation with valve positioners
- Unit construction lets you service the Model 4500A without removing it from the line.
- Canadian Registration Number (CRN) certification for all territories and provinces.

Operating Principles

When signal pressure on the top of the Signal Diaphragm creates a downward force on the Diaphragm Assembly, the Supply Valve opens. Output pressure flows through the Outlet Port and the Aspirator Tube to the Control Chamber to create an upward force on the bottom of the Control Diaphragm. When the setpoint is reached, the force of the signal pressure that acts on the top of the Signal Diaphragm balances with the force of the output pressure that acts on the bottom of the Control Diaphragm to close the Supply Valve.

When the output pressure increases above the signal pressure, the Diaphragm Assembly moves upward to close the Supply Valve and open the Exhaust Valve. Because the Poppet Valve is closed, pressure flows down the Connecting Tube to the bottom of the Motor Diaphragm. This pressure keeps the Supply Valve tightly closed while in the exhaust mode. The Poppet Valve opens and excess output pressure exhausts through the vent in the side of the unit until it reaches the setpoint.

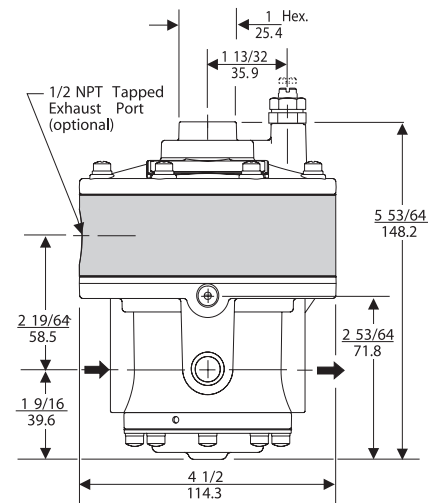
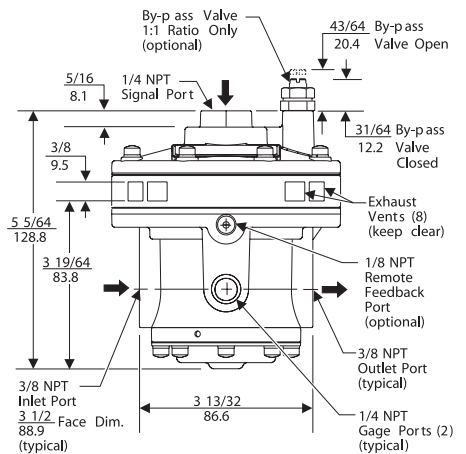
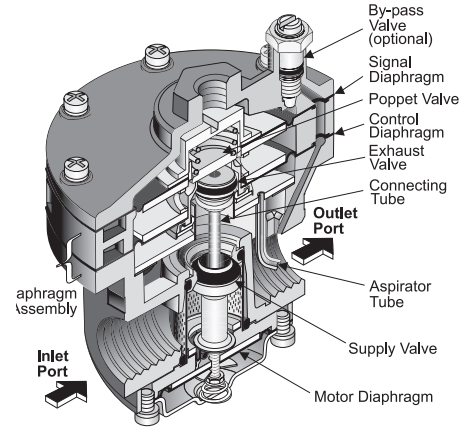

Model 4500A Pneumatic Volume Booster

Technical Information

Forward & Exhaust Flow Characteristics
Fairchild Model 4514A

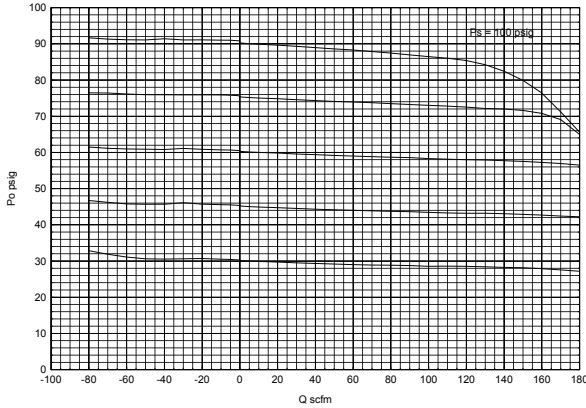

Specifications

	RATIO	1:1	1:2	1:3	2:1	3:1
Maximum Output Pressure	psig [BAR] (kPa)	150 [10.0] (1000)	150 [10.0] (1000)	150 [10.0] (1000)	75 [5.0] (500)	50 [3.5] (350)
Maximum Supply Pressure	psig [BAR] (kPa)	250 [17.0] (1700)	250 [17.0] (1700)	250 [17.0] (1700)	250 [17.0] (1700)	250 [17.0] (1700)
Flow Capacity 100 psig, [7.0 BAR], (700 kPa) supply, 20 psig, [1.5 BAR], (150 kPa) setpoint.	SCFM m ³ /HR	150 (255)	150 (255)	150 (255)	150 (255)	150 (255)
Exhaust Capacity Downstream Pressure 5 psig, [.35 BAR], (35 kPa) above 20 psig, [1.5 BAR], (150 kPa) setpoint.	SCFM m ³ /HR	40 (65.2)	40 (65.2)	40 (65.2)	40 (65.2)	40 (65.2)
Setpoint Water Column	(cm)	1" (2.54)	2" (5.08)	3" (7.62)	2" (5.08)	2" (5.08)
Ratio Accuracy % of 100 psig, [7.0 BAR], (700 kPa) output span.		3.0	3.0	3.0		
% of output span with 100 psig, [7.0 BAR], (700 kPa) input span					3.0	3.0
Supply Pressure Effect	psig [BAR] (kPa)	0.10 [.007] (0.7)	0.20 [.014] (1.4)	0.30 [.021] (2.1)	0.10 [.007] (0.7)	0.10 [.007] (0.7)

Ambient Temperature
-40°F to 200°F, (-40°C to 93.3°C)

Hazardous Locations
Acceptable for use in Zones 1 and 2 for gas atmosphere; Groups IIA and IIB and Zones 21 and 22 for dust atmospheres

Materials of Construction
Body and Housing Aluminum
Trim Zinc Plated Steel, Brass
Diaphragm Nitrile on Dacron

Catalog Information

Catalog Number	4 5	<input type="checkbox"/>	<input type="checkbox"/>	A	<input type="checkbox"/>	
Ratio	1:1	1:2	1:3	2:1	3:1	
	1	2	3	4	5	
Pipe Size	3/8" NPT	1/2" NPT	3/4" NPT	3	4	6



Options	Tapped Exhaust	E
By-pass Valve ¹		I
Feedback		P
BSPT (Tapered)		U
BSPP (Parallel) ²		H
Viton Elastomers ³		J
Stainless Steel Trim		S

¹ For 1:1 Ratio Only
² BSPP Threads in Inlet, Outlet, Exhaust & Bonnet Ports Only. Others BSPT
³ Available on 1:1, 1:2 and 2:1 Only

Installation

For installations instructions, refer to the corresponding Fairchild Model 4500A Pneumatic Volume Booster Instruction, Operation and Maintenance Instructions, IS-2004500A.

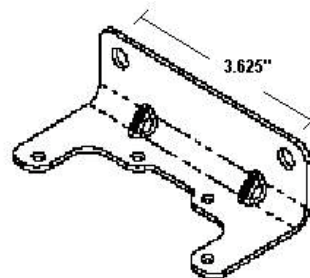

Model 4500A Mounting Bracket Kit P/ N 20555-1 zinc plated (sold separately)