

A Model 81 Multi-Stage Pressure Regulator

Model
81



Features

- Outstanding sensitivity
- Droop or boost virtually eliminated
- Fast response
- Minimal effect for supply pressure change
- High forward flow capacity
- High exhaust capacity
- Small physical size, saves space
- Sapphire orifice
- Permits use in instrumentation and control applications
- Provides constant output pressure over large flow range
- Eliminates output pressure excursions
- Reduces time to exhaust
- Reduces abrasive effects of air

Operating Principles

This Model 81 is a precision two-stage regulator that combines a pilot control system with a basic force balance system to provide accurate output pressure regulation.

It is recommended for use in both highly sensitive instrumentation and control circuits and in equipment requiring high flow with precise control.

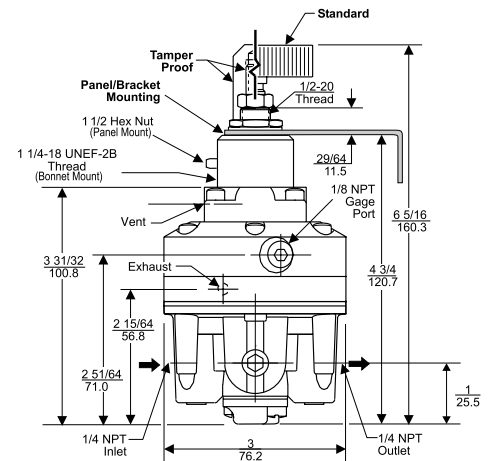
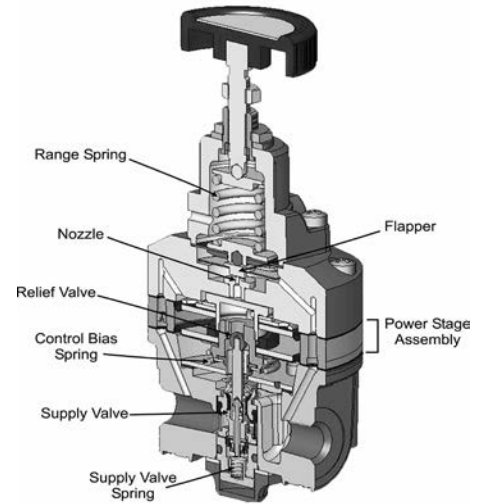

Model 81 Multi-Stage Pressure Regulator



Model 81

Technical Information

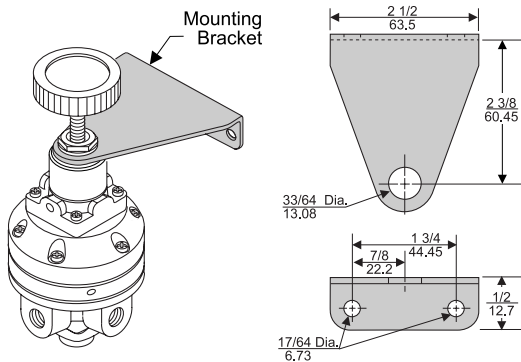
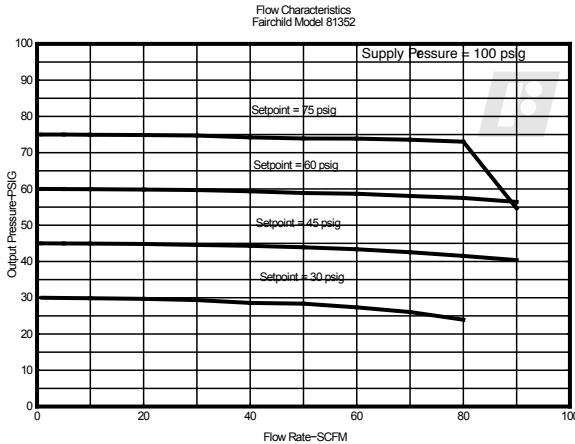

Mounting Bracket: 11989

Model 81 Regulator Kits & Accessories

Mounting Bracket Kit 11989 (sold separately)

Catalog Information

Catalog Number **814** -

Pressure Ranges

psig	[BAR]	(kPa)	
0-2	[0-0.15]	(0-15).....	1
0-5	[0-0.35]	(0-35).....	2
0-20	[0-1.5]	(0-150).....	3
0.5-60	[0.035-4]	(3.5-400)....	4
0.5-100	[0.035-7]	(3.5-700)....	5

Pipe Size

1/4" NPT 2

Options

Tapped Exhaust E
 Bonnet Mounting P
 Tamper Proof T
 BSPT (Tapered) U

Service Information

A service kit is available for the Model 81. Refer to the *Installation, Operation and Maintenance Instructions*, IS-10000081.

Specifications

Flow Capacity (nominal)

50 SCFM (85 m³/HR) (100 psig, [7.0 BAR], (700 kPa) supply; 20 psig, [1.5 BAR], (150 kPa) setpoint)

Exhaust Capacity

5.5 SCFM (9.4 m³/HR) Downstream pressure 5 psig [.35 BAR] (35 kPa) above setpoint

Maximum Supply Pressure

2, 5 psig, [.15, .35 BAR], (14, 35 kPa) ranges:
100 psig, [7.0 BAR], (700 kPa)

20, 60, 100 psig, [1.5, 4.0, 7.0 BAR], (140, 400, 700 kPa) ranges:
150 psig, [10.0 BAR], (1000 kPa)

Minimum Supply Pressure

20 psig, [1.5 BAR], (150 kPa)

Maximum Output Pressure

100 psig, [7.0 BAR], (150 kPa)

Pressure Change (due to supply pressure variation)

Less than .2 psig, [.13 BAR], (150 kPa) for 100 psig, [7.0 BAR], (700 kPa) change

Air Consumption

Less than 0.1 SCFM (1.7 m³/HR)

Sensitivity

Less than 0.1" (.254 cm) Water Column

Ambient Temperature Limit

-40°F to +200°F, (-40°C to 93°C)

Materials of Construction

Body Die Case Aluminum
 Trim ... Stainless Steel, Brass, Aluminum, and Plated Steel
 Diaphragms Nitrile on Dacron
 Orifice Sapphire