

Model T7800 Electro-Pneumatic I/P, E/P Transducer

Features

- The T7800 Series Transducers provide maximum versatility for precision applications.
- Field Reversible Feature provides output that is inversely proportional to input signal.
- RFI/EMI Protection eliminates susceptibility to electromagnetic and radio interference.
- Internal Electronic Feedback and solid state controlled Piezoelectric Actuator provide precise control of output pressure regardless of vibration or position.
- Damping Adjustment for optimum tuning response.
- Split range operation lets a common signal source control two or more functions.
- Compact size for use in restricted spaces.
- Various mounting configurations allow installation flexibility for most applications.
- NEMA 4X, Type 4 Enclosure and IP65 rated for indoor and outdoor installations.
- Canadian Registration Numbers (CRN) certification for all territories and provinces.

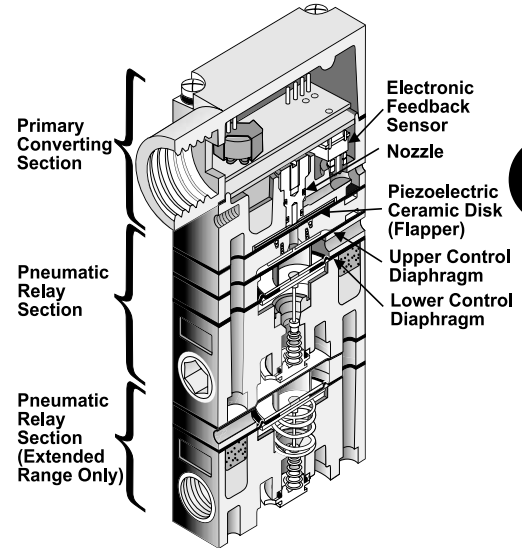

B
Model T7800

Operating Principles

STANDARD RANGE

The Model T7800 Series converts a DC input signal to a linear proportional pneumatic output. It includes the Primary Converting Section and the pneumatic Relay Section. The Piezoelectric Ceramic Actuator, in the Primary Converting Section, functions as a Flapper. The Flapper and Nozzle work together to control the signal pressure. The signal pressure that sets the output pressure acts on the Upper Control Diaphragm in the Pneumatic Relay Section. The Lower Control Diaphragm in the Pneumatic Relay Section senses the output pressure.

EXTENDED RANGE

In the Extended Range units, an additional Relay Section amplifies the output pressure.

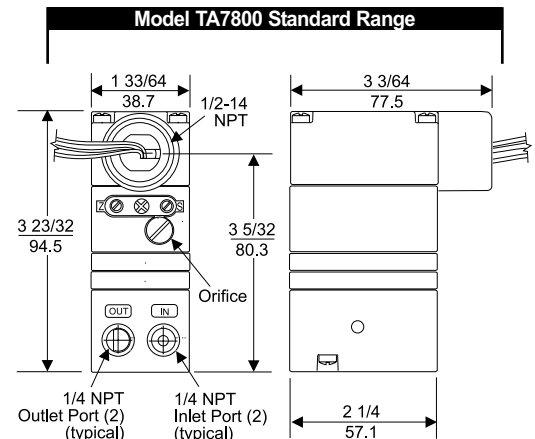

Note: Unused IN and OUT Ports are plugged (typical)

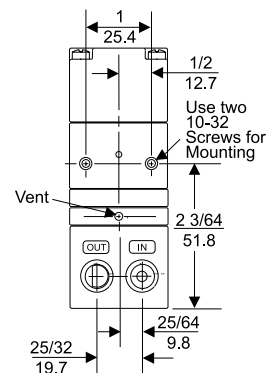

Model T7800 Electro-Pneumatic I/P, E/P Transducer

B
Model T7800

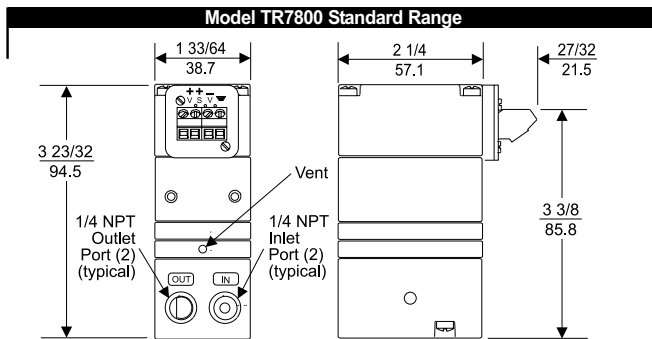
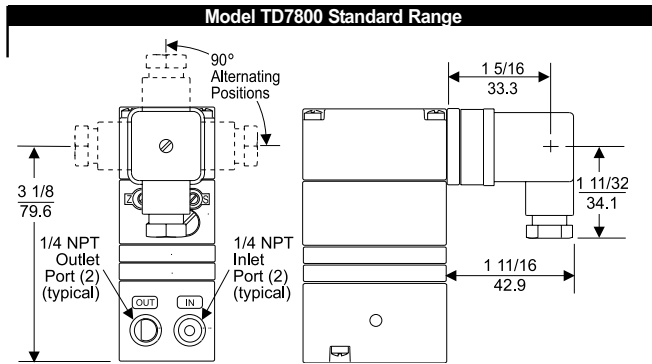
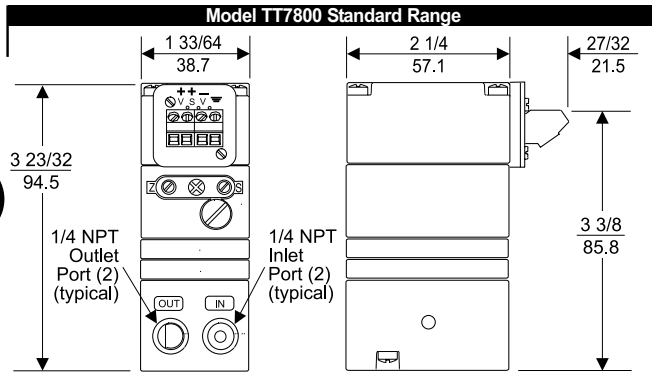

Model TR7800 for use with TR Manifold Rack Kit. TR7800 unit same as TT7800 except terminal block is located on rear.

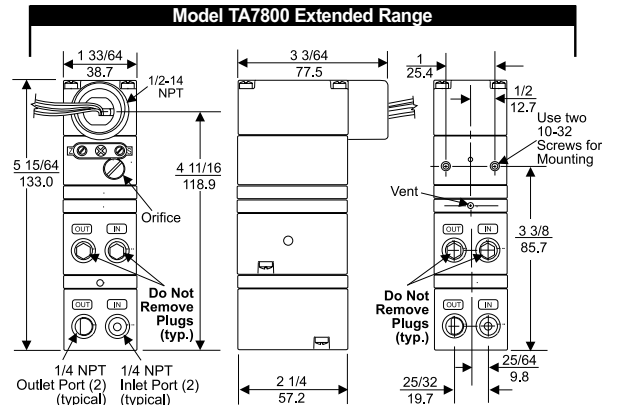

Note: Unused IN and OUT Ports are plugged (typical)

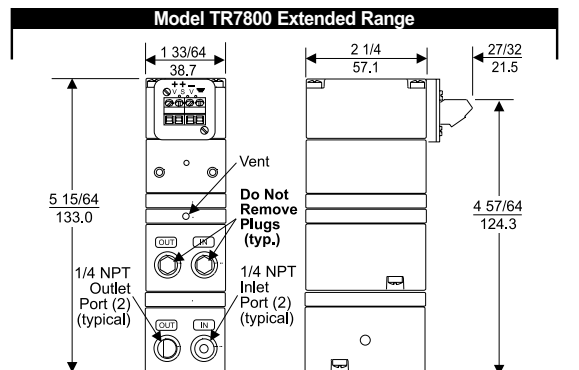
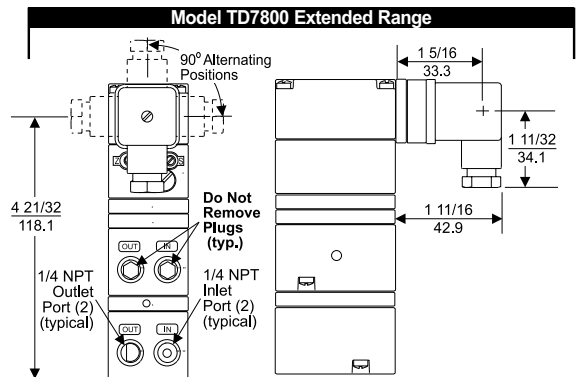
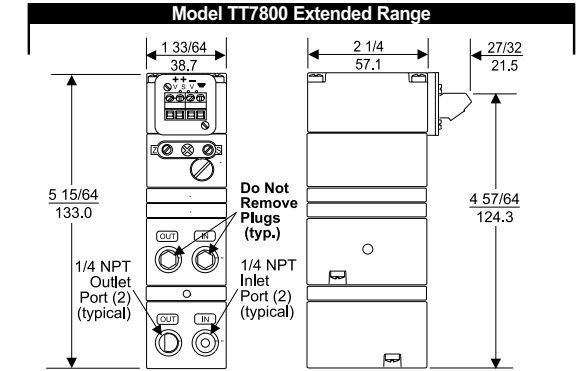

Model TR7800 for use with TR Manifold Rack Kit. TR7800 unit same as TT7800 except terminal block is located on rear.

Model T7800 Electro-Pneumatic I/P, E/P Transducer

Standard Range Specifications		SET POINT			
		3 [0.2] (20)	9 [0.6] (60)	15 [1.0] (100)	30 [2.0] (200)
Maximum Air Consumption	All Ranges SCFH	3.5 (.10 m ³ /HR)	7.0 (.20 m ³ /HR)	9.5 (.27 m ³ /HR)	13.5 (.38 m ³ /HR)
Flow Rate (SCFM)		2.5 (4.25 m ³ /HR) @ 25 psig, [1.7 BAR], (170 kPa) supply & 9 psig, [0.6 BAR], (60 kPa) Output		OR	9.0 (15.3 m ³ /HR) @ 120 psig, [8.0 BAR], (800 kPa) supply & 9 psig, [0.6 BAR], (60 kPa) Output
Temperature Range	Operating Storage	-40°F to + 160°F (-40°C to + 71.2°C) -40°F to + 180°F (-40°C to + 82.2°C)			
Span/Zero Adjustments		Screwdriver adjustments located on front of unit			
Required Operating Voltages		Two Wire Current Input 7.2 VDC @ 20 mA (4-20 mA signal)			
Supply Voltages		Three Wire Voltage Input 7.2-30 VDC, less than 3 mA			
Signal Impedance		Three Wire Voltage Input 10 Kilohms			
		OUTPUT RANGE			
		3-15 [0.2-1.0] (20-100)	3-27 [0.2-1.8] (20-180)	6-30 [0.4-2.0] (40-200)	
Input Range		4-20 mA DC, 0-10 VDC, 1-9 VDC			
Supply Pressure ¹		20-120 [1.5-8.0] (150-800)	32-120 [2.2-8.0] (220-800)	35-120 [2.4-8.0] (240-800)	
Minimum Span		5 [0.35] (35)	10 [0.7] (70)	10 [0.7] (70)	
Frequency Response		-3 db @ 5 Hz per ISA S26.4.3.1 load configuration A.			
Accuracy (ISA S51.1)		0.25% Full Scale Guaranteed 0.15% Full Scale Typical			
Hysteresis (ISA S51.1)		0.1% Full Scale			
Deadband		0.02% Full Scale			
Repeatability (ISA S51.1)		0.1% Full Scale			
Position Effect		No Measurable Effect			
Vibration Effect		Less than +1% of Span under the following conditions: 5-15 Hz @ 0.8 inches constant displacement 15-500 Hz @ 10 Gs.			
Reverse Polarity Protection		No damage occurs from reversal of normal supply current (4-20 mA) or from misapplication of up to 60 mA.			
RFI/EMI Effect		Less than 0.5% of span @ 30 %m class 3 Band ABC (20-1000 mHz) per SAMA PMC 33.1 1978 and less than 0.5% of Span @ 10 %m level, to 2 GHz Band per EN 61000-4-3:1998 +A1 EMC Directive 89/336/EEC European Norms EN 61326			
Supply Pressure Effect		No Measurable Effect			
Temperature Effect		[+0.5% +0.04% / °F Temperature Change] of Span typical			
Materials of Construction		Body and HousingChromate Treated Aluminum OrificeNickel Plated Brass & Sapphire TrimStainless Steel, Brass & Zinc Plated Steel ElastomersNitrile FinishEpoxy Powder Coating			



¹ Supply Pressure must be no less than 5 psig, [0.35 BAR], (35 kPa), above maximum output

Model T7800 Electro-Pneumatic I/P, E/P Transducer

B
Model
T7800

Extended Range Specifications		SET POINT				
	psig [BAR] (kPa)	0 [0] (0)	15 [1.0] (100)	30 [2.0] (200)	60 [4.0] (400)	120 [8.0] (800)
Maximum Air Consumption	0-30 psig SCFH	3.1 (.09 m ³ /HR)	7.8 (.22 m ³ /HR)	11.8 (.33 m ³ /HR)		
	0-60 psig SCFH	1.6 (0.4 m ³ /HR)	4.7 (.13 m ³ /HR)	7.8 (.22 m ³ /HR)	13.3 (.37 m ³ /HR)	
	0-120 psig SCFH	0.5 (.01 m ³ /HR)		3.8 (.11 m ³ /HR)	7.6 (.21 m ³ /HR)	15.1 (.42 m ³ /HR)
Flow Rate (SCFM)		11.0 (18.7 m ³ /HR) @ 150 psig, [10 BAR], (1000 kPa) supply & midscale output				
Temperature Range	Operating Storage	-40°F to + 160°F, (-40°C to + 71.2°C) -40°F to + 180°F, (-40°C to + 82.2°C)				
Span/Zero Adjustments		Screwdriver adjustments located on front of unit				
Required Operating Voltages		Two Wire Current Input 7.2 VDC @ 20 mA (4-20 mA signal)				
Supply Voltages		Three Wire Voltage Input 7.2 - 30 VDC, less than 3 mA				
Signal Impedance		Three Wire Voltage Input 10 Kilohms				
	psig [BAR] (kPa)	OUTPUT RANGE				
		0-30 [0-2.0] (0-200)	0-60 [0-4.0] (0-400)	0-120 [0-8.0] (0-800)		
Input Range		4-20 mA DC, 0-10 VDC, 1-9 VDC				
Supply Pressure ¹		35-150 [2.4-10] (240-1000)	65-150 [4.6-10] (460-1000)	125-150 [8.8-10] (880-100)		
Minimum Span		12.5 [0.85] (85)	25 [1.5] (150)	50 [3.0] (300)		
Frequency Response		-3 db @ 2 Hz per ISA S26.4.3.1 load configuration A.				
Accuracy (ISA S51.1)		0.25% Full Scale Guaranteed 0.15% Full Scale Typical				
Hysteresis (ISA S51.1)		0.25% Full Scale				
Deadband		0.02% Full Scale				
Repeatability (ISA S51.1)		0.1% Full Scale				
Position Effect		0.125% @ 90° & 0.25% @ 180°				
Vibration Effect		Less than +1% of Span under the following conditions: 5-15 Hz @ 0.8 inches constant displacement 15-500 Hz @ 10 Gs.				
Reverse Polarity Protection		No damage occurs from reversal of normal supply current (4-20 mA) or from misapplication of up to 60 mA.				
RFI/EMI Effect		Less than 0.5% of span @ 30 %m class 3 Band ABC (20-1000 mHz) per SAMA PMC 33.1 1978 and less than 0.5% of Span @ 10 %m level, to 2 GHz Band per EN 61000-4-3:1998 +A1 EMC Directive 89/336/EEC European Norms EN 61326				
Supply Pressure Effect		< 0.1 psig change for 10 psig supply change				
Temperature Effect		[+0.5% +0.06% / °F Temperature Change] of Span typical				
Materials of Construction		Body and HousingChromate Treated Aluminum OrificeNickel Plated Brass & Sapphire TrimStainless Steel, Brass & Zinc Plated Steel ElastomersNitrile FinishEpoxy Powder Coating				

¹ Supply Pressure must be no less than 5 psig, [0.35 BAR], (35 kPa), above maximum output

Model T7800 Electro-Pneumatic I/P, E/P Transducer

Hazardous Area Specifications

	Intrinsically Safe (4-20 mA Only)	Division 2														
Factory Mutual (FM) Approvals <table border="1"> <tr> <td colspan="2">Entity Parameters</td> </tr> <tr> <td>Vmax¹ = 30 VDC</td> <td>Ci³ = 0 μ F</td> </tr> <tr> <td>Imax² = 200 mA</td> <td>Li⁴ = 0 mH</td> </tr> <tr> <td>¹Vmax = Max. Voltage</td> <td>³Ci = Capacitance</td> </tr> <tr> <td>²Imax = Max. Current</td> <td>⁴Li = Inductance</td> </tr> </table>	Entity Parameters		Vmax ¹ = 30 VDC	Ci ³ = 0 μ F	Imax ² = 200 mA	Li ⁴ = 0 mH	¹ Vmax = Max. Voltage	³ Ci = Capacitance	² Imax = Max. Current	⁴ Li = Inductance	TDFI7800, TAFI7800 Class I, Division 1, Groups C and D; Class II, Division 1, Groups E, F and G; Class III, Division 1, Fibers; NEMA 4X Enclosure; Temperature Code T4, T _{amb} = -20 °C to 65 °C	TDFI7800, TAFI7800, TDFN7800, TAFN7800 Class I, Division 2, Groups A, B, C and D; Suitable for Class II, Division 2, Groups F and G; Class III, Division 2; NEMA 4X Enclosure; Non-Incendive 4-20 mA, voltage input units ; Temperature Code T4.				
Entity Parameters																
Vmax ¹ = 30 VDC	Ci ³ = 0 μ F															
Imax ² = 200 mA	Li ⁴ = 0 mH															
¹ Vmax = Max. Voltage	³ Ci = Capacitance															
² Imax = Max. Current	⁴ Li = Inductance															
<table border="1"> <tr> <td colspan="2">Non-Incendive Field Wiring Parameters</td> </tr> <tr> <td>Vmax¹ = 30 VDC</td> <td>Ci³ = 0 μ F</td> </tr> <tr> <td></td> <td>Li⁴ = 0 mH</td> </tr> <tr> <td>¹Vmax = Max. Voltage</td> <td>³Ci = Capacitance</td> </tr> <tr> <td></td> <td>⁴Li = Inductance</td> </tr> </table>	Non-Incendive Field Wiring Parameters		Vmax ¹ = 30 VDC	Ci ³ = 0 μ F		Li ⁴ = 0 mH	¹ Vmax = Max. Voltage	³ Ci = Capacitance		⁴ Li = Inductance	TTFI7800, TRFI7800 Class I, Division 1, Groups C and D; Temperature Code T4, T _{amb} = -20 °C to 65 °C	TTFI7800, TRFI7800, TTFN7800, TRFN7800 Class I, Division 2, Groups A, B, C and D; Non-Incendive 4-20 mA, voltage input units; Temperature Code T4.				
Non-Incendive Field Wiring Parameters																
Vmax ¹ = 30 VDC	Ci ³ = 0 μ F															
	Li ⁴ = 0 mH															
¹ Vmax = Max. Voltage	³ Ci = Capacitance															
	⁴ Li = Inductance															
Canadian Standards Association (CSA) Approvals <table border="1"> <tr> <td colspan="2">Approvals are valid when connected through a Shunt Zener Diode Safety Barrier meeting the following parametric requirements:</td> </tr> <tr> <td>System Type 1: Single Channel Polarized Rated: 28.5V Max. 300 Ohm Min.</td> <td></td> </tr> <tr> <td>System Type 2: Dual Channel Polarized Rated 28.5V Max. 300 Ohm Min. and 10V Max. 50 Ohm Min.</td> <td></td> </tr> <tr> <td>System Type 3: Dual Channel Polarized Rated: 28.5V Max. 300 Ohm Min. and 28V Diode return per channel</td> <td></td> </tr> </table>	Approvals are valid when connected through a Shunt Zener Diode Safety Barrier meeting the following parametric requirements:		System Type 1: Single Channel Polarized Rated: 28.5V Max. 300 Ohm Min.		System Type 2: Dual Channel Polarized Rated 28.5V Max. 300 Ohm Min. and 10V Max. 50 Ohm Min.		System Type 3: Dual Channel Polarized Rated: 28.5V Max. 300 Ohm Min. and 28V Diode return per channel		TDCI7800, TACI7800 Class I, Division 1, Groups C and D; Class II, Division 1, Groups E, F and G; Type 4 Enclosure; Rated 4-20 mA, 30 VDC maximum; Temperature Code T6.	TDCI7800, TTCI7800, TRCI7800 Class I, Division 2, Groups A, B, C and D; Rated 4-20 mA, 30 VDC maximum; Temperature Code T6.						
Approvals are valid when connected through a Shunt Zener Diode Safety Barrier meeting the following parametric requirements:																
System Type 1: Single Channel Polarized Rated: 28.5V Max. 300 Ohm Min.																
System Type 2: Dual Channel Polarized Rated 28.5V Max. 300 Ohm Min. and 10V Max. 50 Ohm Min.																
System Type 3: Dual Channel Polarized Rated: 28.5V Max. 300 Ohm Min. and 28V Diode return per channel																
	TTCI7800, TRCI7800 Class I, Division 1, Groups C and D; Rated 4-20 mA, 30VDC maximum; Temperature Code T6.	TACI7800 Class I, Division 2, Groups A, B, C and D; Class II, Division 2, Groups E, F and G; Type 4 Enclosure; Rated 4-20 mA, 30 VDC maximum; Temperature Code T6.														
ATEX Approvals <table border="1"> <tr> <td colspan="2">Transducer Parameters</td> </tr> <tr> <td>Umax¹ = 28 V</td> <td>Pi³ = 0.7 W</td> </tr> <tr> <td>Imax² = 100 mA</td> <td>Ci⁴ = 0</td> </tr> <tr> <td></td> <td>Li⁵ = 0</td> </tr> <tr> <td>¹Umax = Max. Voltage</td> <td>³Pi = Max. Power</td> </tr> <tr> <td>²Imax = Max. Current</td> <td>⁴Ci = Capacitance</td> </tr> <tr> <td></td> <td>⁵Li = Inductance</td> </tr> </table>	Transducer Parameters		Umax ¹ = 28 V	Pi ³ = 0.7 W	Imax ² = 100 mA	Ci ⁴ = 0		Li ⁵ = 0	¹ Umax = Max. Voltage	³ Pi = Max. Power	² Imax = Max. Current	⁴ Ci = Capacitance		⁵ Li = Inductance	TAEI7800, TDEI7800 EEx ia IIB, T4, T _{amb} = -20 °C to 72 °C Ⓢ II 1G (T4), II 1D (T85 °C) IP65 Enclosure	
Transducer Parameters																
Umax ¹ = 28 V	Pi ³ = 0.7 W															
Imax ² = 100 mA	Ci ⁴ = 0															
	Li ⁵ = 0															
¹ Umax = Max. Voltage	³ Pi = Max. Power															
² Imax = Max. Current	⁴ Ci = Capacitance															
	⁵ Li = Inductance															
	TTEI7800, TREI7800 EEx ia IIB, T4, T _{amb} = -20 °C to 72 °C Ⓢ II 1G (T4)															

B
Model T7800



Model T7800 Electro-Pneumatic I/P, E/P Transducer

Mounting Kits

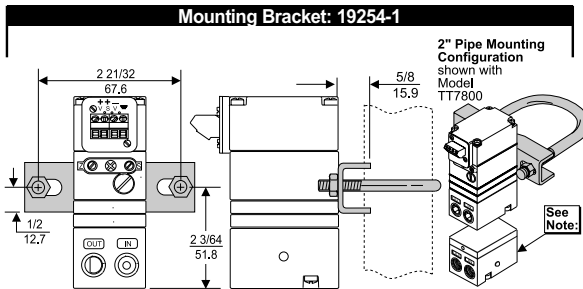
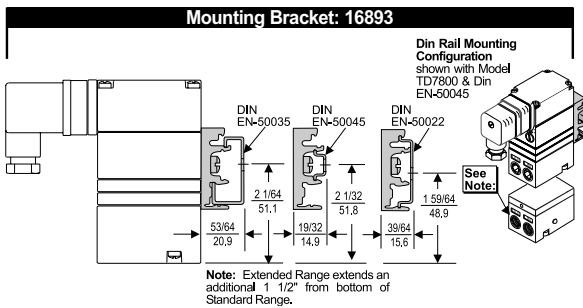
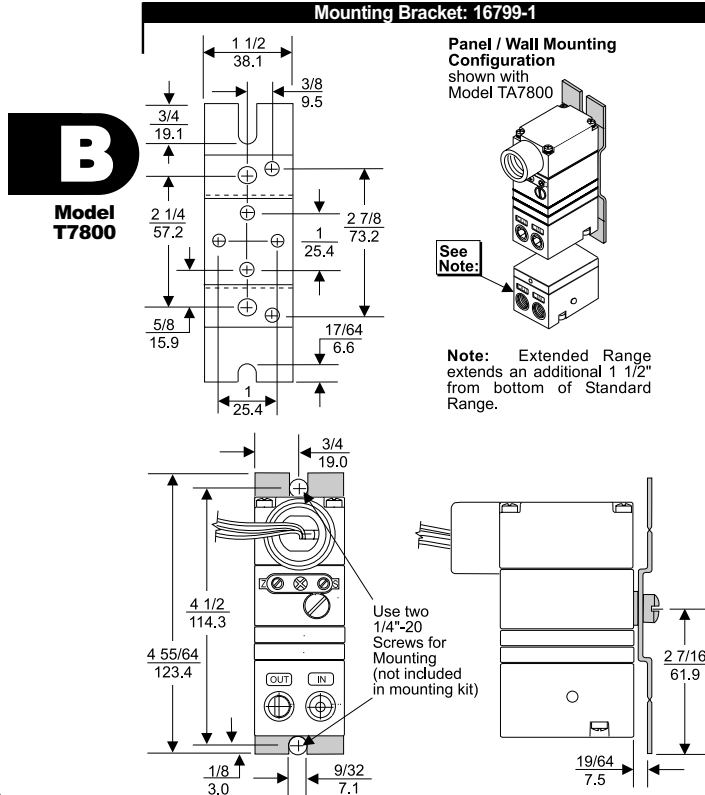

Model T7800 Transducer Kits & Accessories

Mounting Bracket Kits16799-1 (included with unit)
16893 (included with unit)
19254-1 (sold separately)

Catalog Information

Catalog Number T **7800**

Electrical Connections

1/2 NPT Conduit A
Fitting with Pigtail D
DIN43650 Connection R
Rack Mount T
Terminal Block

Underwriting Group

Canadian Standards C
ATEX E
Factory Mutual F
None (leave blank)

Approval Class

Intrinsically Safe¹ I
Non-Incendive (Division 2)² N
None (leave blank)

Input

4-20 mA 4
1-5 VDC⁶ 5
0-5 VDC⁶ 7
1-9 VDC 9
0-10 VDC 0

Output

3-15 psig³ 01
3-27 psig³ 02
6-30 psig³ 03
0-30 psig⁴ 04
0-60 psig⁴ 05
0-120 psig⁴ 06
[0.2-1.0 BAR]³ 11
[0.2-1.8 BAR]³ 12
[0.4-2.0 BAR]³ 13
[0-2.0 BAR]⁴ 14
[0-4.0 BAR]⁴ 15
[0-8.0 BAR]⁴ 16
(20-100 kPa)³ 21
(20-180 kPa)³ 22
(40-200 kPa)³ 23
(0-200 kPa)⁴ 24
(0-400 kPa)⁴ 25
(0-800 kPa)⁴ 26

Options

BSPT Thread⁵ U

¹ Intrinsically Safe Approval includes Non-Incendive (Division 2), available on 4-20 mA units only.

² Non-Incendive (Division 2) approval on FM voltage input units only

³ Standard Range

⁴ Extended Range

⁵ Available on all units EXCEPT Factory Mutual and Canadian Standards Underwriting Group units.

⁶ Limited Availability

Installation

For installation instructions, refer to the *Fairchild T7800 Standard Range Electro-Pneumatic Transducer Installation, Operation and Maintenance Instructions, IS-50T7800S* and the *Fairchild T7800 Extended Range Electro-Pneumatic Transducer Installation, Operation and Maintenance Instructions, IS-50T7800E*.

Optional manifolds are available to mount 3, 5, 10 or 15 transducers. An optional rack kit is available to mount 10 transducers in a standard 19" rack. For more information, see the *Fairchild Manifold and Rack Kit, CS-400MRKT*.